



GIANT SERIES

CHILDREN INTERACTIVE WORKSTATION

Why should children be any different? Here at Ergovida, the children's work is their play and we want our products to encourage children to find a love for learning, creating and invention. The children interactive workstation provides a large smooth surface for activities, plenty of storage space for books, paints and other arts & crafts supplies. This all-in-one desk also means ultimate usability for your little tyke.



WARRANTY



ERGONOMICS



Forget Sit Down



Concerned about your child's health and wellness? Here is an interesting article from CNN that should hit home for those of us with kids, or planning to have kids in the future — "A lot of kids at our school literally lacked the hip range motion to get into the sack and then were having difficulty jumping," said Starrett, "really freaked us out because we realized the only thing that could cause that kind of dysfunction in kids was sitting too much."

Forget 'Sit down!' Students now standing up to learn, 2015, Kelly Wallace (CNN's digital correspondent and editor-at-large covering family, career and life)

It was easy to see that **sitting still all day**, coupled with sitting at meal times, sitting for homework, and sitting to watch TV or play video games **relates to movement dysfunction at an early age**. Moreover, the studies show that many kids are sedentary as much as 80% to 90% of the time they're awake, and over a lifetime, sitting for more than six hours a day increases the risk of death. **Standing can increase both fitness and attention spans**.

While the concept of standing desks is still a new one in education, our sit-to-stand workstation appears to be a response moving away from the traditional "sitting all the time" approach to a standing and moving environment.

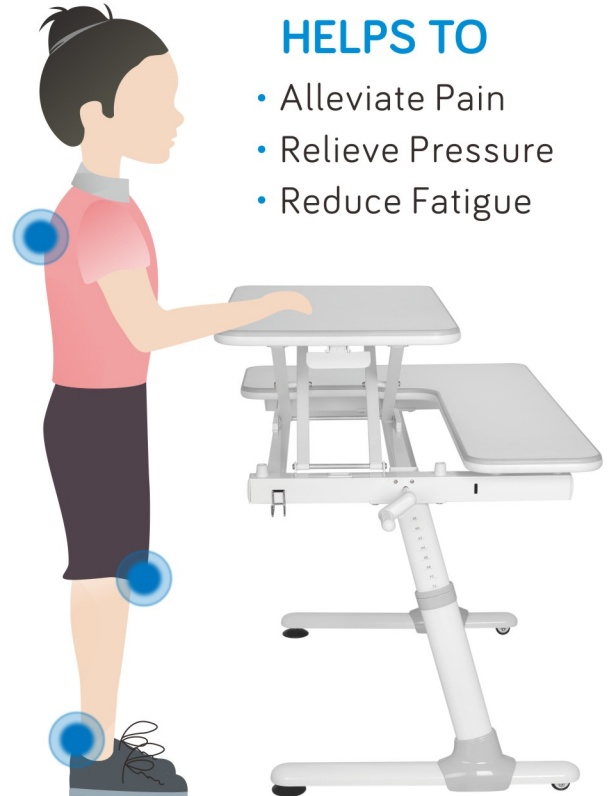

FEATURES

- ① **Squeeze Handle**
lets you quietly and effortlessly adjust the lift top from seated to standing position in just seconds, as well as gradually and smoothly lowering it thanks to its spring-loaded bumper

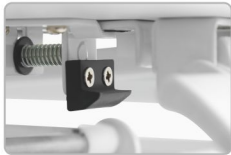

- ② **Crank Handle**
makes it easier to adjust the desk height



- ③ **Anti-Pinch Safety Design**
ensures little hands are not pinching when the tabletop is lifted



- ④ **Pull-Out Compartmented Drawer**
organizes and stores books, papers, stationery, coloring utensils, etc.



- ⑤ **Multi-Functional Steel Hook**
for schoolbag or any other hanging items



Safe Materials for Peace of Mind



E505 White Board Lift Top with Side Surface • Compartment Drawer

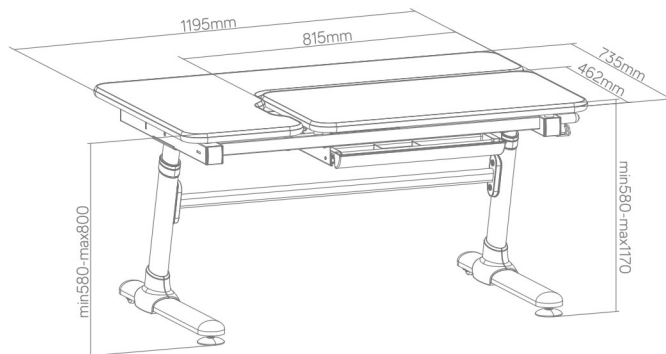

Non-Reflection
Surface



Crank Handle



Anti-Pinch
Safety Design



Multi-Function
Hook



Large Legroom



Feet Leveler



Feet Caster

Desktop Material: Particle Board E1 Grade

Desktop Thickness: 25mm

Full Desktop Size: 1195x735mm

Lift Desktop Size: 815x462mm

Desk Height Adjustment Range: 580-800mm

Height Adjustment Mechanism: Crank Handle

Color:   

E501 White Board Tiltable Top with Rear Surface • Compartment Drawer

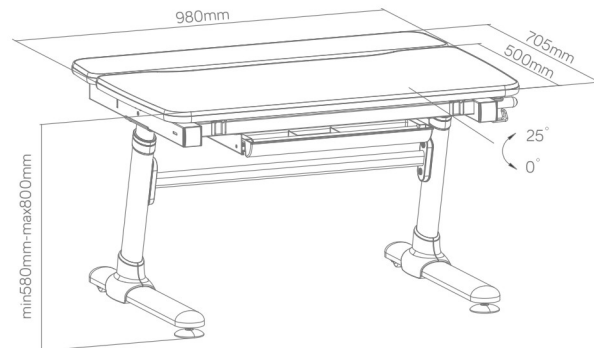

Non-Reflection
Surface



Crank Handle



Anti-Pinch
Safety Design



Multi-Function
Hook



Large Legroom



Feet Leveler



Feet Caster

Desktop Material: Particle Board E1 Grade

Desktop Thickness: 25mm

Desktop Tilt Range: 0-25°

Full Desktop Size: 980x705mm

Tilting Desktop Size: 980x500mm

Desk Height Adjustment Range: 580-800mm

Height Adjustment Mechanism: Crank Handle

Color:   

E501W Wood Grain Tilttable Top with Rear Surface • Compartment Drawer

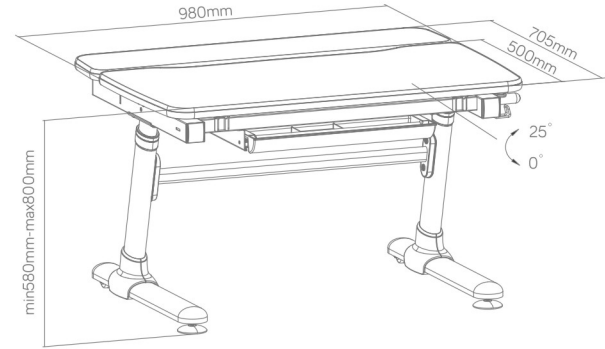

Non-Reflection Surface



Crank Handle



Anti-Pinch Safety Design



Multi-Function Hook



Large Legroom



Feet Leveler



Feet Caster

Desktop Material: Particle Board E1 Grade

Desktop Thickness: 25mm

Desktop Tilt Range: 0-25°

Full Desktop Size: 980x705mm

Tilting Desktop Size: 980x500mm

Desk Height Adjustment Range: 580-800mm

Height Adjustment Mechanism: Crank Handle

Color:   

E502 White Board Tiltable Top with Side Surface • Compartment Drawer

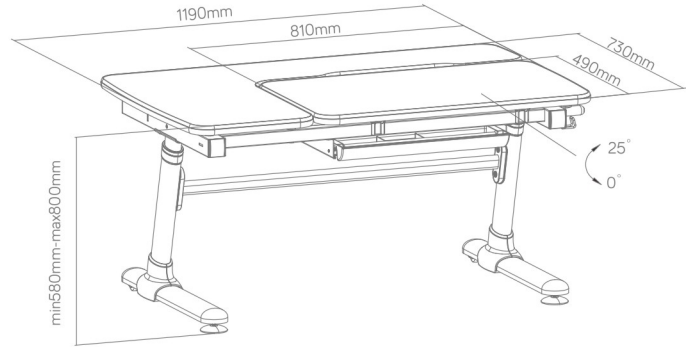

Non-Reflection
Surface



Crank Handle



Anti-Pinch
Safety Design



Multi-Function
Hook



Large Legroom



Feet Leveler



Feet Caster

Desktop Material: Particle Board E1 Grade

Desktop Thickness: 25mm

Desktop Tilt Range: 0-25°

Full Desktop Size: 1190x730mm

Tilting Desktop Size: 810x490mm

Desk Height Adjustment Range: 580-800mm

Height Adjustment Mechanism: Crank Handle

Color:   

E502W Wood Grain Tiltable Top with Side Surface • Compartment Drawer

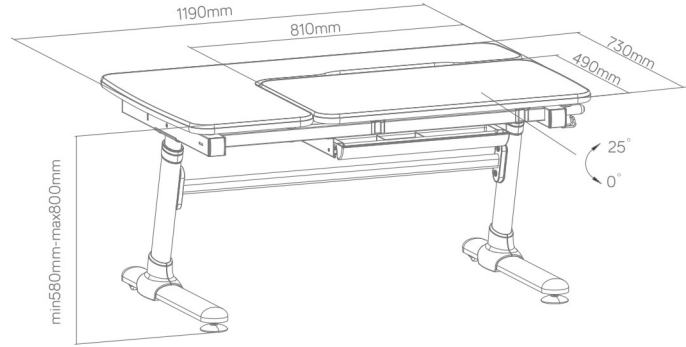

Non-Reflection Surface



Crank Handle



Anti-Pinch Safety Design



Multi-Function Hook



Large Legroom



Feet Leveler



Feet Caster

Desktop Material: Particle Board E1 Grade

Desktop Thickness: 25mm

Desktop Tilt Range: 0-25°

Full Desktop Size: 1190x730mm

Tilting Desktop Size: 810x490mm

Desk Height Adjustment Range: 580-800mm

Height Adjustment Mechanism: Crank Handle

Color:   

E503 White Board Tiltable Top with Side Surface • Compartment Drawer

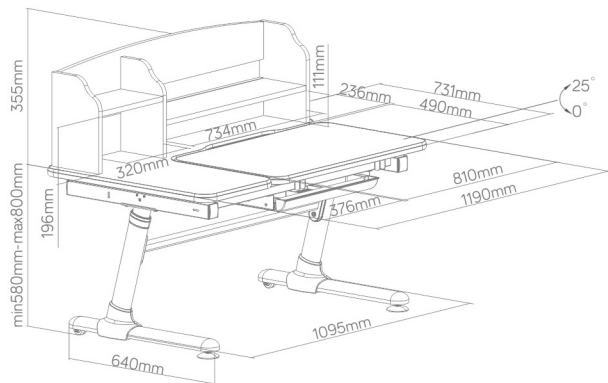

Non-Reflection
Surface



Crank Handle



Book Shelf



Anti-Pinch
Safety Design



Multi-Function
Hook



Large Legroom



Feet Leveler



Feet Caster

Desktop Material: Particle Board E1 Grade

Desktop Thickness: 25mm

Desktop Tilt Range: 0-25°

Full Desktop Size: 1190x731mm

Tilting Desktop Size: 810x490mm

Desk Height Adjustment Range: 580-800mm

Height Adjustment Mechanism: Crank Handle

Color:   

E504 White Board Tiltable Top with Rear Surface • Compartment Drawer

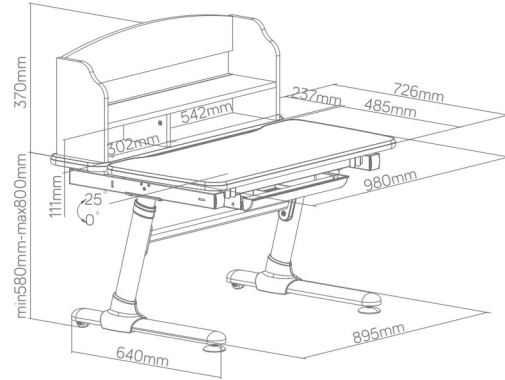

Non-Reflection Surface



Crank Handle



Book Shelf



Anti-Pinch Safety Design



Multi-Function Hook



Large Legroom



Feet Leveler



Feet Caster

Desktop Material: Particle Board E1 Grade

Desktop Thickness: 25mm

Desktop Tilt Range: 0-25°

Full Desktop Size: 980x726mm

Tilting Desktop Size: 980x485mm

Desk Height Adjustment Range: 580-800mm

Height Adjustment Mechanism: Crank Handle

Color:   

NINGBO ERGOVIDA HEALTH TECHNOLOGY LTD.

a LUMI LEGEND GROUP company

Tel: +86-0574-28860060 Fax: +86-0574-27956598 E-mail: info@ergovida.cn

Add: 22/F., Building 1, Lisi Plaza, Huifeng East Road, Ningbo, China 315100



Visit
Our Website

www.ergovida.cn

